

C1/SfB		
(31.39)	Yt4	(K2)

Date: August 1998

Price: £5.00

The Role of Intumescent Materials in Timber and Metal Based Fire Resisting Glazing Systems

The Intumescent Fire Seals Association

ifsa



Glass and Glazing Federation

CONTENTS

Introduction	3
Fire safety	
Fire resistance	
Smoke control	
Impact resistance	
Intumescent Products for Glazing	4
Behaviour of intumescent	
Durability	
Glass Types	5
Non-insulating glass	
<i>Wired glass</i>	
<i>Borosilicate glass</i>	
<i>Ceramic</i>	
<i>Coated Modified Toughened Soda-lime glass</i>	
<i>Modified Soda-lime glass</i>	
<i>Laminated Safety glass</i>	
<i>Super Toughened Fire/Security glasses</i>	
Insulating glass	
<i>Intumescent Laminated glass</i>	
<i>Gel glass</i>	
Types of Construction to be glazed	8
Timber Screens	
<i>Timber Screen without Mullions</i>	
<i>Timber Glazing Details - Non-insulating glass</i>	
<i>Timber Glazing Details - Insulating glass</i>	
Metal Constructions	
<i>Metal Frames - Non-insulating glass</i>	
<i>Metal Frames - Insulating glass</i>	
Fire resisting doors	
<i>Timber door leaves</i>	
<i>Steel door leaves</i>	
Summary	11

THE ROLE OF INTUMESCENT MATERIALS IN TIMBER AND METAL BASED FIRE RESISTING GLAZING SYSTEMS

INTRODUCTION

This IFSA/GGF information sheet summarises the performance characteristics of intumescent materials in respect of their application in fire resistant glazing systems. It is intended to give guidance to specifying and controlling authorities, fire prevention officers, door and screen manufacturers and builders on the use of intumescent fire seals in fire resistant glazing both in doors and screens made from either timber or steel.

Fire Safety

Current legislation permits the use of glass products in building although, because of the need to maintain high levels of separation between some areas and to maintain unhindered escape routes, the use of non-insulated glass may be restricted in certain areas.

Glass has many positive attributes in terms of providing a fire safe building. It is essentially non-combustible and therefore complies with all the legislative requirements for surface spread of flame. As a sheet material, it will not permit smoke to penetrate nor will it produce smoke during the critical developing phase of a fire.

However, glass that is installed in a glazing pocket, whether in wood, steel or concrete without gaskets or seals would have a significantly reduced ability to resist smoke penetration. Gaskets intro-

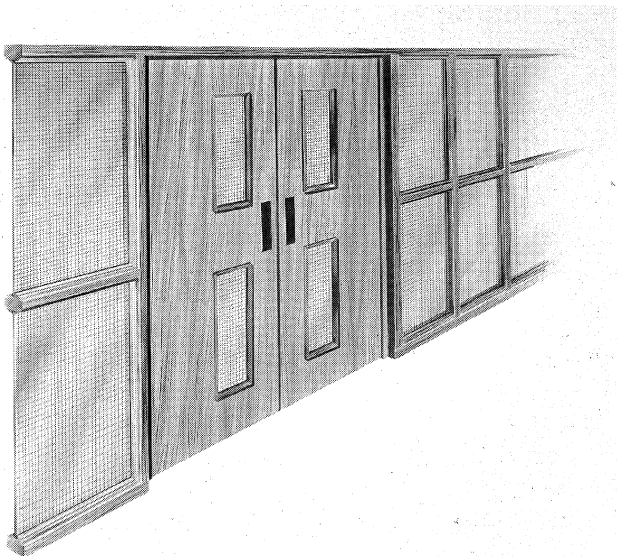

duced to restrict the passage of noise and odours, or to limit the effect of vibrations, could generate significant volumes of smoke, if incorrectly specified, and could certainly compromise both the non-combustibility and zero surface spread of flame characteristics of the glass. As the fire temperature rises and the glazing system is put under stress the hot gases will readily exploit a badly designed glazing detail.

An intumescent based glazing seal can ensure that the natural attributes of glass are maintained by preserving the integrity of the glazing pocket. Intumescent seals can expand to accommodate any deterioration in the glazing pocket and therefore play a significant role in achieving fire safety with a glazed screen or door.

Fire Resistance

The fire resistance of a glazed element is determined by exposing it to the standard heating and pressure conditions of BS 476: Part 20. The glass and its surroundings are evaluated for both insulation from the unexposed face temperature rise and for the loss of integrity.

Insulation

The insulation criteria are very stringent and the temperature rise of separating elements must not exceed 180°C anywhere on the surface nor shall the mean temperature, as determined by a number of prescribed thermocouples, exceed a rise of 140°C. With a 6mm thick uninsulated glass, there is no chance of satisfying the insulation criteria for more than a few minutes. This is also true of standard steel framing members as not only does the level of heat transfer cause the critical temperature to be exceeded, but any combustible materials in the glazing system are adversely affected.

Integrity

Loss of integrity is defined in BS476: Part 20 by one of the following criteria:

- a) continuous flaming for more than 10 seconds on the unexposed face;
- b) glowing or flaming of an oven-dried cotton pad when placed into the gas stream issuing from any gap or crack;
- c) the development of gaps exceeding 150x6mm or 25mm diameter as determined by gap gauges.

The cotton pad cannot be used on uninsulated assemblies because the cellulose fibres will ignite under the influence of radiation emitted from the unexposed face of a non-insulated system within

about 25 minutes from the start of a fire resistance test. While intumescent glazing edge seals cannot directly do anything to help glass satisfy the insulation criteria, they can make a major contribution in maintaining integrity at the perimeter of the glass. Non-insulated glass rarely fails integrity in the centre of the pane but gaps may develop at the perimeter of the panel.

Such gaps are normally associated with deterioration of the glazing system and intumescent materials can compensate for this by expanding to fill any gaps that start to develop. After approximately 35 to 45 minutes, gaps at the perimeter normally result in bead ignition. From about 50 minutes onwards the glass will either pull out from the sides or from the head of the frame unless it is adequately restrained. One way of achieving this is to keep the edge of the pane stiff by keeping the glass below its softening temperature. Intumescent materials are well suited to this task although some products are better than others in this respect.

Smoke Control

BS476: Part 31.1 describes a method of testing the ability of fire doors to control smoke leakage. It is a test for the whole door assembly and not just the edge seals. Measurements are carried out at 25Pa pressure and intumescent glazing products can prevent a glazed aperture from increasing the overall leakage rate of the door.

Impact resistance

Ordinary glass is a brittle material which shatters easily but its impact resistance is greatly improved by toughening, laminating or by the introduction of reinforcing wires. The requirements for the safe use of glass are set out in Approved Document N of the Building Regulations. The impact resistance of glass is classified in BS6026: 1981 *Specification for impact performance requirements for flat safety glass and safety plastics for use in buildings* and the glass products described in this information sheet have all been classified according to the requirements of this standard.

INTUMESCENT PRODUCTS FOR GLAZING

There are three basic types which are related to the chemicals used in their formulation:-

1. Hydrated sodium silicate
2. Graphite
3. Mono-ammonium phosphate (MAP)

All these materials expand on heating but behave rather differently in other respects.

Behaviour of Intumescent

Activation of seals based on hydrated sodium silicate occurs at about 110°C to 120°C with the release of water vapour from within the molecular structure as the material dehydrates. The intumesced sodium silicate forms a crack free foam which is highly resistant to erosion and which eventually hardens under fire conditions. The overall expansion is several times that of the original volume and the intumescent product generates a high pressure when constrained.

Graphite seals intumesce at temperatures of about 170°C and upwards depending upon the grade. Graphite expands to many times its original volume if unrestrained but when contained within a gap the expanded graphite particles interlock thus providing a firm matrix. The expanded graphite is capable of resisting the turbulence within the furnace and of developing a medium to very high positive pressure when constrained, depending upon the grade used. Care must be taken to ensure the correct grade is selected for a glazing seal, backed up by test reports.

Mono-ammonium phosphate based intumescent materials are multicomponent systems which interact at approximately 180°C. The complex reactions produce a soft 'doughy' product and the expansion may vary from small to very large depending upon the formulation. The intumesced products generate very low pressures but high expansion versions are self-insulating so they continue to react over a long period, thereby filling gaps and cracks that develop as the fire progresses.

Durability

Reputable manufacturers, such as the members of IFSA, ensure that their products are designed to last for many years. Some intumescent ingredients such as graphite are inherently stable and are relatively unaffected by atmospheric conditions so that it is not necessary to apply additional protection. Other intumescent, such as hydrated sodium silicate and mono-ammonium phosphate, are hygroscopic and need to be properly protected to prevent deterioration through the absorption of atmospheric moisture. Furthermore, sodium silicate can be converted to sodium carbonate by atmospheric carbon dioxide. The hydrated sodium silicate used in glazing seals is normally made in the form of sheets and is protected from water vapour and carbon dioxide by an impermeable epoxy resin coating applied during manufacture to the major surfaces and edges. When the sheets are cut into strips the cut surfaces have to be coated to maintain this protection and the material is normally encased in a PVC sleeve. Mono-ammonium phosphate compounds can be protected from water vapour by surface coating but it is also

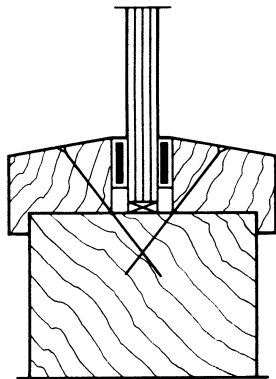

30 minutes

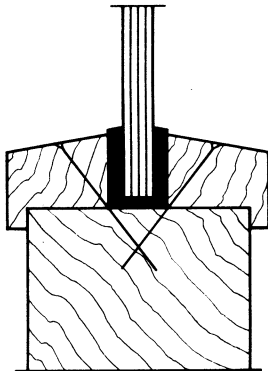

30 minutes

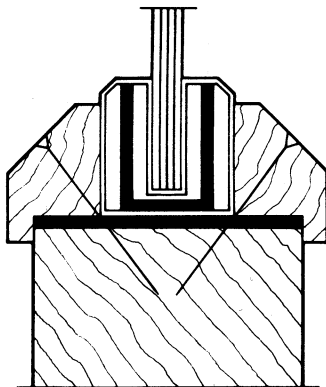

60 minutes

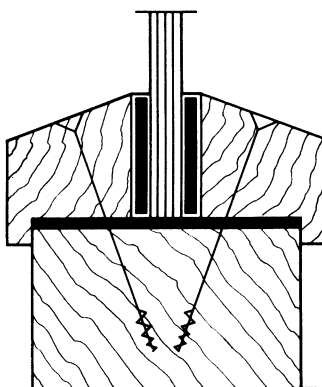

60 minutes

Typical sections through proprietary glazing systems using intumescent seals

possible to prevent deterioration by suitable choice of binder system. This has the advantage that cut surfaces do not need to be protected. It can be seen therefore that there is no technical reason why intumescent materials should not last as long as other building materials, provided that they are purchased from reputable suppliers and their instructions are carried out.

Accelerated ageing tests are being carried out by some manufacturers in IFSA and long-term ageing tests have been underway since 1984. Even when subjected to high relative humidity on a cyclical basis varying between 50 and 85% at 25°C the seals still achieve 30 minutes performance when tested to BS476 Part 23 (see also IFSA Technical Information Sheet No. 4 The Aging Performance of Intumescent Seals).

Graphite and mono-ammonium phosphate based materials are available as gunnable sealants and both types are also produced as preformed tapes. Considerable care must be exercised with gunnable graphite based sealants to ensure that the correct amount of intumescent material is applied to both sides of the glass, otherwise the fire integrity of the glazed unit will be impaired.

The manufacturer's installation instructions must be strictly followed with all types of seals in order to ensure the fire performance of the systems.

GLASS TYPES

In terms of fire resistance, glass can be divided into two main categories, non-insulating and insulating.

Non-Insulating Glass

There are a number of different types available in addition to the long established wired soda-lime glass and heat resisting borosilicate glass. These include ceramic and several types of modified toughened glass have become available as well as hybrid laminates.

Non-insulating glasses have different responses to heat so the amount of edge cover is vitally important and is usually different for the different types of glass. Materials with the lowest coefficient of thermal expansion are the least likely to crack so ceramic is most tolerant to high temperature exposure, followed by borosilicate glass. The toughening process helps to make glass more tolerant but toughened soda-lime types are still sensitive to edge cover which is normally not more than 10mm and therefore requires extra care in fitting. Wired soda-lime glass is not toughened and is least tolerant, but in this case performance is unaffected because the

wires maintain the overall stability.

During a fire test all these types remain clear and transmit radiant heat.

Wired Glass

In a fire test carried out to BS476 Part 20, wired glass cracks extensively around its perimeter with a number of dominant cracks across the entire height and width of the pane.

Without integral wires ordinary soda-lime glass will fall from the screen within five minutes from the start of the test. After prolonged exposure to heat the glass softens and starts to flow under its own weight causing a gap to develop at the head of the pane, thereby producing an integrity failure.

Wired glass can be made to satisfy integrity in areas up to 3.5m² for 30 minutes depending on the glazing details and the safety version has achieved a 30 minute rating in the maximum size available, 5m². At higher performance levels, between 60 and 90 minutes, the behaviour of the glass is very much dependent on size of the pane, its height-to-width ratio, and the glazing detail.

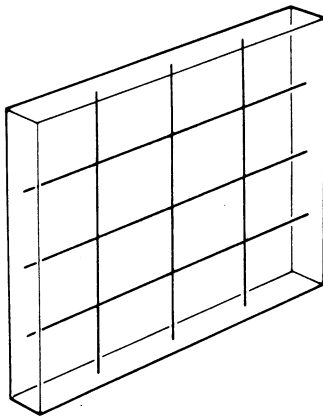

Wired glass (soda lime)

Borosilicate Glass

Borosilicate glasses do not crack when heated in accordance with BS 476: Part 20 as they are able to tolerate higher surface temperature differentials than soda-lime glass because of their lower thermal expansion. As a consequence they do not require wire reinforcement to ensure that they maintain integrity and they can be used with little restriction on edge cover. These glasses soften at higher temperatures than soda-lime glass but extended exposure to elevated temperatures eventually leads to softening and slumping. Consequently integrity failure generally occurs by the formation of gaps at the top of a pane.

At the 30 minute fire rating borosilicate glasses

can be used up to their maximum manufactured size using approved intumescent glazing details. At the 60 - 180 minute performance level the behaviour depends on the pane size and the glazing system used.

Ceramic

Ceramic 'glass' has been available for some time and as its name suggests it is quite different in composition from either wired soda-lime or borosilicate glass. The product is a transparent, but with a slight brownish tint, sheet of ceramic material, 5mm thick. It has a significantly higher softening temperature than the other glasses and it is therefore capable of withstanding a much longer exposure to fire conditions without slumping.

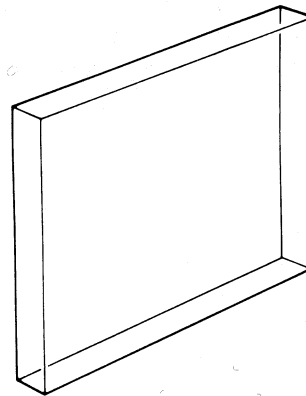

Unwired glass (borosilicate, ceramic, toughened)

The glass has satisfied the integrity requirement of BS 476: Part 22 for more than 3 hours. The ceramic has a high resistance to thermal shock because of an extremely low expansion coefficient. This low thermal expansion combined with a high softening temperature means that the amount of edge cover needed is not critical to the fire performance so it is usually less than that of other commercially available glasses. Unlike glass this product cannot be toughened so it is not able to meet the impact resistance requirements of BS 6206 and its use in some areas is therefore restricted. It can however be laminated to grade A safety glass where required. Unlike most unwired clear fire glasses, it can be cut with conventional tools and individual panes do not have to be made to order.

Coated Modified Toughened Soda-lime Glass

Developments over the last few years have demonstrated that edge controlled clear soda-lime modified toughened glass, with a metallic coating applied to both faces during production, is able to achieve in excess of 90 minutes integrity when glazed into a suitable framing system.

These glasses do not suffer to the same degree as

un-coated products from low tolerance of thermal gradients, however care must be taken when glazing, as these glasses should only be fitted in accordance with the manufacturer's instructions. Particular care is needed if the glass is coated on one side only. Since this product is asymmetrical it can only be used where the fire risk side is known and the glass must be installed with the coating on this side. Care should be taken when selecting the types of glazing materials to be used and only tested or assessed products compatible with these glasses should be installed.

Modified Soda-lime Glass (Toughened Clear Float)

Toughened, clear, soda-lime glass is able to achieve in excess of 30 minutes integrity both in timber and steel frames and even 60 minutes has been achieved in a steel frame. However, these glasses have a very low tolerance to thermal gradients and consequently the edge cover to the glass is critical. Such glasses should only be fitted in accordance with the manufacturer's recommendations.

Intumescent products with both their high expansion and natural insulation characteristics can produce higher thermal gradients than this type of glass can tolerate and should only be used if they are approved by the glass or intumescent manufacturer.

Laminated Safety Glass

Glasses are often laminated for safety or security purposes and often these are also required to be fire resisting. A common combination will be the use of a float glass laminated to wired glass with polyvinyl butyral or a cast-in-place resin interlayer.

When heated the float glass will fail rapidly, normally due to excessive thermal gradients, but the wired glass will remain within the opening providing a fire resistant membrane. It is important that the glazing pocket is not left so open after the loss of the non-fire glass that it compromises the integrity of the fire glass.

Super Toughened Fire/Security Glasses

Recent developments have seen the introduction of modified soda-lime glasses capable of achieving either 30 or 60 minutes integrity, depending on the framing method and size, and coupled with a substantial degree of resistance to physical attack. These glasses rely on edge control and care should be taken when glazing to ensure that the glasses are fixed sufficiently to ensure they are not pushed out of the frame, but without excessive edge cover which may result in thermal failure. Such glasses should only be fitted in accordance with the manufacturer's recommendations.

Insulating Glass

Whilst the non-insulating glasses referred to above will reduce the radiation emitted by the fire to some extent, they will not satisfy the BS 476: Part 20 insulation criterion for more than a few minutes. If the glass has to comply with the full criteria of integrity and insulation, as it may if it is installed in a compartment wall, then one of the clear multi-ply insulating glasses will be required. There are two forms; one has intumescent layers interleaved with glass (intumescent laminated glass) and the other has an aqueous gel sandwiched between two panes of glass (gel glass).

These products will normally have been tested with insulating frames but sometimes there is a requirement to use them with non-insulating frames. In this case it is essential to ascertain whether the product has been tested in a non-insulating frame or whether it has been assessed for such use.

Intumescent Laminated Glass

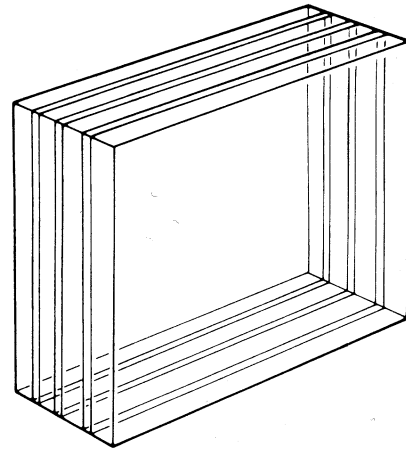

Laminated glass

Intumescent laminated glasses consist of layers of float glass interleaved with clear hydrated sodium silicate intumescent material. Increasing the number of intumescent layers within the glass increases the performance. On heating, the exposed layer of float glass cracks and the first layer of intumescent is activated. This effectively makes the glass opaque thus reducing the transmission of radiated and conducted heat through the glass. As the intumescent layer expands the front layer of float glass may become detached from the pane. The intumescent used produces a large volumetric expansion and creates a 'meringue' on the exposed face. With time the exposed intumescent is degraded by the hot gases in the furnace and the heat is conducted through the 'meringue' thus causing the next layer of glass to crack and the second layer of intumescent to be activated.

This procedure continues until there are no more layers of intumescent to activate. When fire testing

this type of glass, it can be seen that the glass on the unexposed surface remains reasonably cool and therefore does not slump.

Failure is generally caused by a combination of the glass cracking and creating a locally weak spot in the intumescent 'meringue' which is subsequently eroded by the hot gases. Integrity failure will ultimately be caused by the formation of a gap in the pane. Unlike non-insulating glasses it is unusual for the glass to fail at the edge of the pane because the unexposed surface temperature does not exceed 180°C above ambient. These types of glass can provide up to 2 hours fire resistance.

At the lower end of the range intumescent laminated glasses have been produced with only one active layer. These provide a 30 minute integrity in reasonable sized panes up to 2m² but they may only satisfy the insulation criterion for nominally 15 minutes.

Gel Glass

Unlike the laminated glasses where the intumescent interlayer is of solid form and in the region of 1.5mm in thickness, the gel glasses incorporate a reservoir of clear insulating gel up to 13mm thick which is retained between 2 or more layers of toughened glass. Glasses are available with 30 and 60 minutes performance with respect to integrity and insulation.

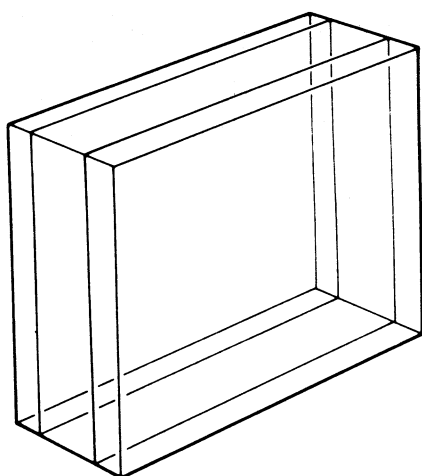

Gel glass

TYPES OF CONSTRUCTION TO BE GLAZED

Timber Screens

One of the first decisions facing the designer of a timber glazed screen is whether to use hardwood or softwood for the framing and beads. Strictly speaking this difference is not relevant since the

density of the timber is the most important factor. However, higher density timbers (>650kg/m³) are generally hardwoods and lower density timbers (420 - 650kg/m³) are generally softwoods in spite of a number of exceptions. It is in this sense that these terms 'hardwood' and 'softwood' are used in this document. The rate of charring is a density related property with higher density timbers charring more slowly than the lower density species.

As a rough guide hardwoods char at a rate of 0.5mm/minute and softwoods char at a rate of 0.66 to 0.75mm/minute. However these figures are the rates observed at the centre of large flat panels and the rate at which a section becomes depleted is dependent upon its shape, cross-sectional dimensions as well as the density.

Timbers with a density in excess of 650kg/m³ do exhibit a lower rate of charring and need greater heat energy to ignite them than lower density timbers. There are obvious advantages therefore in using the higher density in preference to the lower density woods. Screen members can be smaller in cross-section and can accept greater exposure to heat before failing integrity by flaming. Hardwoods also frequently exhibit straight grain which makes the material stable and predictable although some of the highest density timbers can suffer from spiral or interlocked grain with a resultant likelihood of distortion when heated.

It is possible to use softwood beads for 30 minute non-insulated glazing but hardwood beads are preferable for the reasons given above. When softwood beads are used it is necessary to choose an intumescent system which is suitable for this material. For 60 minute non-insulated applications virtually all the existing test evidence is with hardwoods but a recent development has shown that it is possible to achieve 60 minute performance with softwood beads and framing. Whichever system is used the density, number and type of fixings and intumescent glazing system need to be strictly controlled. The properties of the intumescent are critical to the performance of the system and even products of the same generic type should not be substituted. Advice should be sought from the product manufacturer and the recommendations should be backed up with test evidence.

The designer's final choice will be governed by two major considerations; whether the glass is one of the insulating types or one of those that cannot comply with insulation for the duration of the required fire resistance. The need for, and the nature of, intumescent glazing products will depend upon the selected combination of period of fire resistance and glass type. Whatever combination is specified the fixings used will play an important part in the achievement of the desired rating.

Timber Screen without Mullions

A recent development has been the introduction of an intumescent seal that can be used with borosilicate glass to make a timber screen without mullions. The borosilicate glass is butt jointed with the specially developed sealant and has achieved in excess of 30 minutes when tested to BS476 Part 22. The glass and intumescent tested form a proprietary system so there should be no substitution of products. It is therefore possible to have glass fire resistant screens of any length with an unimpeded view and this has been particularly beneficial at football grounds.

Timber Glazing Details - Non-Insulating Glass

For a typical 30 minute screen using a non-insulating glass it is advantageous to consider what an intumescent glazing material is expected to contribute. At the furnace temperatures that are reached in a half hour test, the glass should not become soft and the intumescent would not be expected to provide the cool edge to aid stiffness. However, the glazing pocket will become badly eroded by the fire, with the hot face bead being

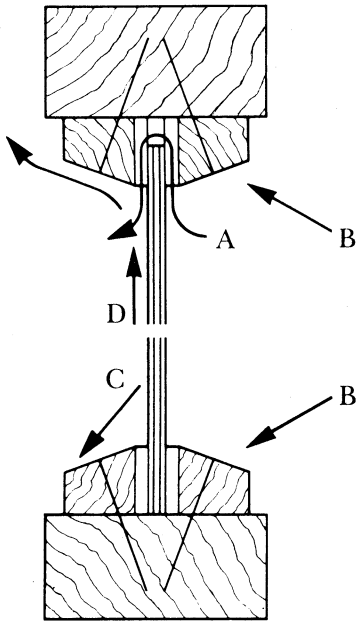

- A. Hot gas flow through imperfections of fit or due to glass slumping from channel.
- B. Fire attack on exposed beads.
- C. Radiated heat attack onto unexposed beads.
- D. Convected heat up the unexposed face of pane.

Routes of Fire Attack to Glazing

converted to charcoal during the first 15 to 20 minutes, but the higher the density the longer the bead will last. It can be seen that for the glass to stay in place after the bead has been degraded, reliance is placed on the other elements of the

glazing system. Even then some movement of the glass will take place and the seal provided by the intumescent material plays an important part in keeping the glass edge free from integrity failure.

Assuming the fixing retains the glass adequately, a major risk with a combustible glazing system is the ignition of the unexposed bead. This would be due to a combination of thermal conduction and radiation passing through the glass and convected heat being generated from the air passing up the unexposed face supplemented by a small component of heat passing through the small gaps inevitably present in a dry glazed system.

To reduce the heat conduction component an insulating material with low air permeability needs to be incorporated between the glass and the beads. An intumescent sealing material is ideal for providing an adequate level of insulation. In addition to the type of wood, the risk of a radiation induced ignition is reduced by one, or a combination of the following measures, depending upon the size of a pane and the duration of the fire resistance:-

- i) The use of an intumescent sealing material to provide a good seal between the glass and the bead. An added benefit is that the expanded foam also serves to protect the bead from radiation.
- ii) The use of an angled bead profile which presents a smaller surface area to the radiation than a flat bead.
- iii) A coating of intumescent paint or varnish to the surface of the bead which protects the timber from direct radiation.

The use of an intumescent seal also helps to reduce the permeability of the glazing system and the angled bead helps to deflect some of the convective gas flow present on the unexposed face, away from the bead.

Most types of intumescent material can be used for 30 minute applications depending upon the pane size, the bead size and material, the type and number of fixings. Increased fire resistance is much more difficult to achieve and some materials are better than others in the expanded state. As many intumescent systems vary in the way they perform, specifiers and installers must ensure that the system they are using has been fire tested or assessed for the intended application. No changes to the tested or assessed system should be introduced as this may well cause a deterioration in performance. Adding more intumescent may not increase performance and in some cases may lead to worse performance through disruption of the beads. Strict adherence to the tested or assessed system is essential in all cases.

The mechanical fixing of the beads also needs careful attention in accordance with test evidence.

Timber Glazing Details - Insulating Glass

When using insulating glasses in softwood screens, there is less of a need for intumescent materials as the risk of the unexposed face beads igniting is reduced by the nature of the glass itself. The glass becomes opaque upon heating thereby greatly reducing the transmitted radiation component and since the cold face of the glass remains below 200°C there is little risk of ignition on the unexposed face. Erosion of the glazing pocket is normally compensated for by the expansion of the intumescent, which also restricts the passage of hot gases. However, the fixings are just as important as with non-insulated glass and must be in accordance with the manufacturer's instructions.

An intumescent fire and smoke glazing seal may be required in normal use to make good any gaps between the glass and the bead and to reduce the permeability of the system with respect to smoke, smells or draughts in the normal cold state.

Metal Constructions

Metal Frames - Non-insulating Glass

In glazing metal frames the intumescent material has a very different function to that required in glazing timber frames. If the glazing system is steel, there is virtually no erosion of the glazing pocket. As before, non-insulating glasses do not soften significantly in tests of 30 minute fire resistance duration. Intumescent materials have two roles to play during this early part of the test. Firstly they can be used to give better smoke leakage results by sealing the glass into the pocket. The second function is not as obvious, but when 6mm non-insulating glass is exposed to the fire it remains brittle for a least the first 20 minutes. The steel glazing framework can bow considerably during this time because of differential temperatures across the section and this bowing can induce additional edge stresses in the glass. If it is tightly glazed with an unwired clear glass, this movement due to bowing could damage the pane leading to early failure. There are several materials including intumescent seals that can be installed between the glass and the framing system which will reduce the stress on the glass edge.

In steel glazing systems that are designed for 60 minutes fire resistance the intumescent plays a much greater role. At the higher temperatures experienced by the glass, softening occurs and there is a danger of the glass slumping out of the bead. This problem is made worse by the high conductivity of the metal framing, which will be at almost the same temperature as the glass. Intumescent products are an ideal solution to the problem of achieving a cold glass edge thereby supporting the softening centre of the

pane. As the intumescent seal gets hot it expands, thus insulating the surface behind the seal from the glass. This is advantageous over many other materials which will reach steady state heat flow at an earlier stage. The high thermal exposure that intumescent seals receive in a metal system where heat is coming from all directions, means that larger cross-sections have to be used in order to delay the material from becoming exhausted.

When used with a stiff glazing pocket, pressure forming intumescent materials can, with specialised design, provide a clamping action on the glass edge which allows the size of the glass pane to be increased beyond that which would be achievable solely by the cool edge. When considering durations in excess of 60 minutes, then the function of the intumescent becomes increasingly important. If taking non-insulating glasses considerably further than their normal softening point would permit, it is important that the glass edge is retained in its position under the bead. This can be done by a suitable adhesive or by the clamping action of a suitable intumescent. The need for pressure is, however, greater than would be applied just by the introduction of pressure forming intumescent in a conventional bead and invariably special manufacturing techniques are incorporated along with the use of a pressure forming intumescent seal. Such techniques are often the subject of patents.

Metal Frames - Insulating Glass

The use of insulating glass in metal frames is similar to that in timber frames. However, if the glass and glazing system is to reach its true potential the screen members should also be insulated as this reduces distortion. There is no absolute need for intumescent material but once more it can make an invaluable contribution to improving the cold smoke leakage. A further consideration with intumescent glazing compounds in insulated assemblies is that the normal core framework is clad with friable materials. Low pressure intumescent compounds based on mono-ammonium phosphate are therefore recommended. The specification of the wrong intumescent may disrupt these claddings which could cause the whole system to break down.

Fire Resisting Doors

At first sight the glazing of fire resisting doors might appear to be rather easier than screens because the glass panes are generally smaller. In fact, doors present a far more complex situation. Whenever possible, fire door leaves should be factory glazed to ensure that all details are correct. In cases where this is impracticable, great care must be taken to ensure compatibility of all the components used.

It should never be assumed that a fire test report covering a glazing system in a timber or steel framed screen will also be valid for a door leaf. Specific test evidence or an assessment by a compe-

tent authority for the size of pane and door type should always be obtained.

Timber door leaves

Timber door leaves fall into two main constructional categories:

- i) "Flush" construction, consisting of a slab core faced with plywood or hardboard and trimmed with hardwood lippings on at least two long edges.
- ii) "Joinery" construction, where traditional techniques are used to make a solid timber frame incorporating either timber or glazed panels.

Within each category, many further variations are possible, all of which may have some influence on the glazing system. Typical fire door thicknesses are 44mm and 54mm and this compares with glazed screen timber frames of 94mm cross section which imparts a much greater stiffness as well as increased burn-through resistance in relation to a door leaf. Furthermore, the framing members for a screen will be rigidly fixed to an inherently stable wall whereas a door leaf is free to move significantly within its frame and will tend to distort under fire exposure. Glazing systems for door leaves therefore need to be tolerant of such movement and flexing.

Distortion can be more pronounced on a solid timber "joinery" door leaf than on a "flush" door construction, and joints can open up or become displaced on fire exposure. This is more likely to be experienced on one hour doors than on half hour doors but as far as the glazing detail is concerned no particular problems are introduced, although a lining strip will be necessary for one hour applications. Similarly, a flush door leaf constructed from a raft of lamels will present few additional problems provided that the glazed aperture is located at least 150mm from any edge.

On the other hand, a flush door leaf using a low density core fitted within a solid timber frame will require specialized attention. If the leaf cannot be factory glazed, then the relevant test report must be called for and the glazing details precisely followed. In particular, the fixing of the glazing beads presents a problem and no deviation from the tested construction is acceptable. Also the intumescent specification must not be altered, as any deviation from the tested components will almost certainly compromise the designed performance under fire exposure.

Intumescent materials often have more than one very important role to fulfil in such applications and compatibility is vital. For example, the low density core, such as chipboard or flaxboard, are permeable to the passage of hot gases and an intumescent liner will generally be necessary to prevent premature breakthrough as the core degrades. The properties of this liner under heat exposure will be critical. In addition there will be considerable dependence on

another intumescent material, not necessarily of the same formulation, to seal the clearance gap between the glazing pocket and the glass itself.

Steel door leaves

Again two distinct constructional types can be identified:

- i) Steel framed constructions enclosed within a sheet steel skin, with or without a special purpose in-fill.
- ii) Hollow rolled steel frame sections designed to be used with large areas of glass and generally similar in profile to those used for adjacent glazed screens.

As in the case of timber, these door leaves are susceptible to relatively high distortions and the appropriate test report specifically for door leaves needs to be identified. Glazing details will be quite specialized for each design and for each glass type under consideration. Once more, it must be stressed that factory glazing is the preferred option, with only fully trained and accredited installers being used if on-site glazing is unavoidable.

SUMMARY

Most fire resisting glazed constructions benefit from incorporating intumescent glazing materials either in strip or sealant form and all can benefit from the improved resistance to cold smoke leakage. In most non-insulating glazed assemblies the intumescent role is vital and in many instances the use of an intumescent is often the only way to achieve the desired period of fire resistance. However, intumescent products have a wide variety of properties and one type should not be substituted with another unless expert guidance has been sought and a written assessment been obtained from a recognised authority.

Sometimes beads are used that are neither timber nor metal. These materials are usually more inert than wood and less prone to distortion than metal. The need for intumescent seals will depend upon the product type and the supplier's recommendations must be strictly followed.

Whilst the above information is given in general terms it is hoped that it will give the specifier some insight into the considerable amount of work and knowledge available to ensure that glazing can be safely used in fire resisting elements. The final message is that only tested combinations of glass, beads, intumescent, frame and fixing methods should be used in order to ensure that the product will achieve the desired performance.

The information submitted in this publication is based on our current knowledge and collective experience of the membership. Whilst every effort is made to ensure the accuracy of advice given, the Associations cannot accept liability for loss or damage arising from the use of the information supplied.

The Intumescent Fire Seals Association **ifsa**
20 Park Street, Princes Risborough, Buckinghamshire HP27 9AH England
Telephone: 01844 275500 Fax: 01844 274002



Glass and Glazing Federation

44-48 Borough High Street, London SE1 1XB
Telephone: 0171 403 7177 Fax: 0171 357 7458